

TP04 - Climbing Structure - Plan 01
@1:100

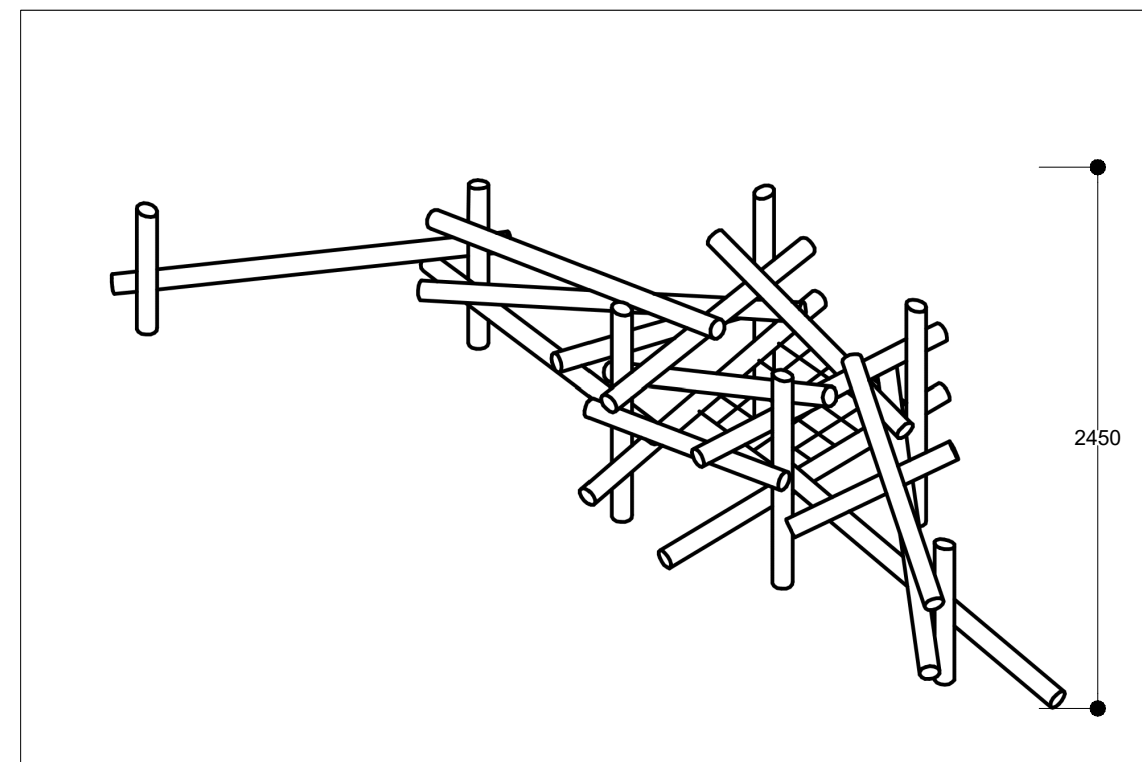

TP04 - Climbing Structure - Image 01
NTS



TP04 - Climbing Structure - Iso 01
NTS

Notes:

Surfacing requirements corresponding to a fall height of ≤ 1.50 m
(please refer to price list for more detailed information)

Installation needs to be carried out by an installation company authorised by Timber Play Ireland. These structures are not-preassembled in the factory like most of the other equipment and the style and organic nature of the timbers means that one is slightly different; therefore expert installation is crucial to ensure compliance of each installation with EN1176, primarily checking entrapment gaps

Rope colour: Natural

Posts made of robinia, dia 150-210mm

Foundations:
7 items 80 x 80 x 60 cm
Excavation depth 80 cm

the paul hogarth company

LANDSCAPE ARCHITECTURE / URBAN DESIGN / PLANNING

e: edinburgh@paulhogarth.com e: belfast@paulhogarth.com e: dublin@paulhogarth.com
t: +44 (0)131 331 4811 t: +44 (0)28 9073 6690 t: +353 (0)1 897 0272

visit us at www.paulhogarth.com find us on: facebook / twitter / instagram / linkedin

notes

Do not scale from drawing, use figured dimensions only.
All dimensions are to be checked on site by contractor prior to commencement of all work.
Discrepancies should be reported immediately.
This drawing is to be read in conjunction with all other TPHC drawings and specification.
This drawing is the copyright of the Landscape Architect and must not be reproduced or used without permission.
Ordnance information base information shown is reproduced from Ordnance Survey material © Crown copyright 2018
Licence Number 100034836.

revision

description

date

author

P01

Planning

27/10/23

EF

created 10/07/23 drawn EF checked AMG scale @ A3 As Shown

project number 1549 drawing number 914 revision P01

client Cavan County Council

project Dun A Rí Natural Play

drawing Landscape Details - Equipment Details 04 of 16

status Planning